

Development of an IoT-based kit to monitor environmental parameters for use in indoor agriculture

Uğur Yegül*

Department of Agricultural Machinery and Technologies Engineering, Faculty of Agriculture, Ankara University, 06135 Ankara, Türkiye

Received:

February 16, 2024

Accepted:

June 24, 2024

Published Online:

July 11, 2024

Abstract

The present study aimed to develop a kit to collect data on important parameters for cultivation in a hydroponic farming environment and send and store these data online. This Study was carried out between February and August 2022. The area where the experiment was conducted is fully controlled (coordinates 39.962013 and 32.867491) and established within Ankara University, Ankara, Türkiye. The kit developed for indoor use in agriculture consisted of a microcontroller, different sensors, and hardware components. For all the hardware to be combined and work properly, a closed box was designed using SolidWorks solid modeling software and fabricated with a 3D printer. The code developed for the kit to fulfill the desired function was written in C++ and transferred to the microcontroller via Arduino software using a personal computer. This kit can measure T (temperature), H (humidity: %), carbon dioxide (CO₂), total volatile organic compounds (TVOC), LUX (luminous intensity: lux), Ultra-violet (UV) W m⁻², P (air pressure: pascal), and AQ (air quality: ppm). The developed kit can transmit and store the data simultaneously on the Internet. IoT technologies need further agricultural studies, and more data to be obtained can contribute to resolving more problems. The kit obtained in the study can be used in domestic agriculture and various agricultural activities.

Keywords: Internet of things, Indoor farming, Arduino, Sensor, Environmental parameters

How to cite this:

Yegül U. Development of an IoT-based kit to monitor environmental parameters for use in indoor agriculture. Asian J. Agric. Biol. xxxx(x): 2024029. DOI: <https://doi.org/10.35495/ajab.2024.029>

*Corresponding author email:
yegul@ankara.edu.tr

This is an Open Access article distributed under the terms of the Creative Commons Attribution 4.0 License. (<https://creativecommons.org/licenses/by/4.0>), which permits unrestricted use, distribution, and reproduction in any medium, provided the original work is properly cited.

Introduction

The Internet of Things (IoT) is a concept we hear frequently and will hear even more about in the future. The concept of IoT, first used in 1999 by Kevin Ashton in a presentation he prepared for a company, has reached a broader vision with the developing technology than the day it emerged. The IoT is a

worldwide network of uniquely addressable objects that communicate with each other through a specific protocol. According to research, it is estimated that 10-11 billion devices are connected to the Internet, which is expected to increase to 50 billion devices by 2022. According to the same research, while the ratio of connected devices per capita globally was 0.08 in 2003, this ratio is estimated to be 6.48 in 2022. It is



also estimated that in 2022, the information traffic generated by 20 typical home devices will be more than all the internet traffic generated in 2008 (Morchid et al., 2023).

IoT mainly collects information such as temperature, humidity, wind, weather, rainfall, soil moisture, electrical conductivity, pH, and nitrogen value. Smart agriculture is the use of different technologies in agricultural activities. Smart-precision agriculture applications with IoT are technologies that can reduce workload and increase yield and quality (Reza et al., 2022).

IoT technologies are extensively used in agriculture in soil quality, irrigation, fertilizer use, and plant diseases. Soil quality, soil moisture, and nitrogen content are determined via Iot. Iot is also used to provide water conservation in irrigation, in the growth of plants, and to prevent unnecessary fertilizer use in fertilization (Corchado, 2018; Bac et al., 2017; Villarrubia et al., 2017), and in automatic spraying machines (Oberti et al., 2016) in disease detection and pesticide administration.

When access to healthy food is critical today, closed systems that use water and other inputs most efficiently while saving space are gaining significant importance. Indoor farming systems stand out as a farming technique that allows efficient and healthy production without being affected by the adverse conditions of nature. Such systems can be applied in different methods such as hydroponics, aeroponics, and aquaponics, and all development conditions required by the plant, such as water, pH, plant nutrients, and temperature, can be controlled at the optimum level (Schnitzler, 2004). The main objective of such systems is to increase the yield and product quality without causing physiological stress to plants, especially in greenhouse conditions. However, minimizing the risks without depending on soil properties is crucial. One of the most essential parameters of indoor agriculture is artificial lighting. Light is the only energy source for photosynthesis. In production systems realized in closed environments, it is possible to increase the yield by controlling plants' photoperiods with artificial lighting. The studies have reported that the highest yield values can be achieved with cold white light and artificial illumination called full spectrum (Bugbee, 2016; Snowden et al., 2016). As a result of the use of soilless agriculture techniques in internal agriculture, it has been determined that less space and water are needed compared to traditional agriculture, and it has been reported that it is possible to reuse water. Thus,

environmental pollution can be reduced, and energy and labor savings can be achieved. The yield from the unit area increases, and year-round production is possible (Rakocy, 2002).

In this study, cultivation was carried out in 9 different experimental plots with 9 different artificial lighting durations in three replications, and the relationships between yield values obtained after harvest and plant growth parameters were evaluated. The traits emphasized were nitrogen balance index (NBI), yield (kg), 331.2 $\mu\text{mol s}^{-1}$ artificial lighting intensity, and 9 different artificial lighting periods (8 hours day^{-1} , 9 hours day^{-1} , 10 hours day^{-1} , 11 hours day^{-1} , 12 hours day^{-1} , 13 hours day^{-1} , 14 hours day^{-1} , 15 hours day^{-1} , 16 hours day^{-1}).

The present study developed an environmental parameter monitoring kit that can be used in indoor agriculture by combining an open-source microcontroller and relatively inexpensive hardware and using the code developed. The kit was designed using solid modelling software (SolidWorks), compacted, and tested under laboratory conditions. The data obtained in a hydroponic cultivation laboratory were transferred to the Internet. The data obtained is also stored on a PC, which can be monitored on line.

The study aimed to develop a kit to collect data on important parameters for cultivation in a hydroponic farming environment and send and store these data online. The Internet can measure temperature, humidity (%), luminous intensity (lux), carbon dioxide (CO_2), total volatile organic compounds (TVOC), Ultraviolet UV (W m^{-2}), and air quality (ppm). The kit can transmit and store the data simultaneously on the Internet. IoT technologies need further agricultural studies, and more data to be obtained can contribute to resolving more problems. The kit obtained in the study can be used in domestic agriculture and various agricultural activities. The hardware used in the kit's design is relatively affordable and easy to use. Six different sensors used in the kit's design facilitate obtaining eight different data and transferring this data to the Internet environment completely free of charge. It was concluded that the kit could operate smoothly and stably and be employed for data recording and early warning for various agricultural activities.

Material and Methods

The kit developed for indoor use in agriculture consisted of an Arduino Mega microcontroller, DHT11 sensor, SGP30 air quality and CO_2 detection



sensor, TSL2561 brightness sensor, GY-8511 ultraviolet sensor, MQ-135 air quality detection sensor, GY-68 BMP180 digital barometric pressure sensor, and a 20x4 LCD Display and ESP8266 wi-fi module. Cables and solder connected the sensors and modules to the microcontroller. For all the hardware to be combined and work stably, a closed box was designed using SolidWorks solid modeling software and produced with a 3D printer. The Arduino Mega microcontroller used in the kit is the most comprehensive Arduino model using the ATmega2560 processor (Arduino, 2023). The code developed for the kit to fulfill the desired function was written in C++ and transferred to the microcontroller via Arduino software using a personal computer.

Six different sensors were used in the kit to fulfill the desired functions. The first of these is a temperature and humidity sensor called DHT11. DHT11 is an affordable alternative to expensive temperature and humidity sensors and can be used in many areas. The sensor provides a maximum sensitivity of $\pm 5\%$ in humidity measurements. Operating with a voltage between 3-5 volts and a maximum current of 2.5 mA, the sensor can measure 0°C and 50°C (Sparkfun, 2023). The sensor is connected to the Arduino Mega microcontroller's digital pin 2 (D2).

Another sensor used is the SGP30 air quality and CO_2 detection sensor, which operates with a voltage of 3.3 volts and a current of 40 mA. The sensor can measure CO_2 concentration from 0 to 60,000 ppm and TVOC concentration from 0 to 60,000 ppb (Makerfabs, 2023). TVOC generally includes organic compounds in the vapor or gas phase. Excessive levels (>2200 ppb) have been reported to irritate the eyes, nose, and throat, causing headaches, loss of coordination, nausea, and damage to the liver, kidneys, and central nervous system (Jia et al., 2019).

TSL2561 brightness sensor was used to determine the artificial lighting intensity in the environment. The sensor operates with a voltage of 3.3 V and a current of 0.6 mA. It has a wide detection range of 0.1 to 40,000 lux (Sparkfun, 2023).

GY-8511 ultraviolet sensor was used to measure the ultraviolet radiation in W m^{-2} . The ML8511 UV sensor can detect light between 280 nm and 390 nm [16]. UV radiation or ultraviolet is the wavelength of the electromagnetic spectrum between 10 nm and 400 nm. There are three main types of UV light. These are called UV-A, UV-B, and UV-C. Between 315 and 400 nm is classified as UV-A, and 280 and 314 nm as UV-B. Plants need UV rays to develop and protect against

fungal diseases (Loconsole and Santamaria, 2021). Another air quality detection sensor, the MQ-135 air quality detection sensor, was added to the kit to detect gases such as sulfur, benzene, water vapor, smoke, etc., in ppm. This sensor performs less accurate measurements than the SGP30 sensor and provides data on the concentration of gases such as NO_x , Benzene, NH_3 , smoke, and CO_2 . The measurement range of the air quality sensor ranges from 10 ppm to 1,000 ppm and operates with a voltage of 5 V (Sparkfun, 2023).

The GY-68 BMP180 digital barometric pressure sensor can measure the pressure in the environment. This sensor is a small sensor that measures air pressure. It has a digital output. Operating with 3.3 V, this sensor also provides height information with an accuracy of up to 0.25 m. It can measure pressure values between 300 and 1100 hPa. It provides altitude information between 500 m and 9,000 m (Sparkfun, 2023).

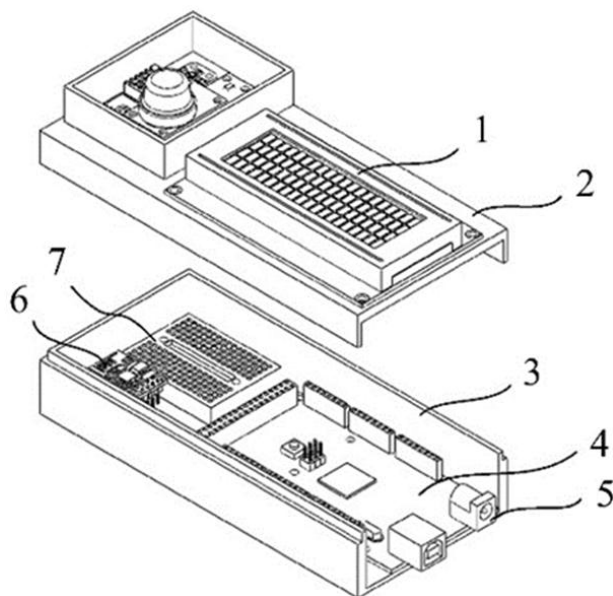

Figure-1. Visualization of the ambient parameters monitoring kit, 1- LCD screen, 2- Top cover, 3- Bottom cover, 4- Arduino Mega microcontroller, 5- 12-Volt supply input, 6- ESP8266 wi-fi module, 7- mini-board

After the code developed for the kit was transferred to the microcontroller using a computer, the hardware and the box design obtained from the three-dimensional printer were assembled. The kit is powered by an external 12 V - 3 A adapter.

The connection of hardware connected to the

microcontroller is as follows. DHT11 temperature and humidity sensor is connected to the digital 2 (D2) pin, SGP30 air quality and CO₂ detection sensor, TSL2561 brightness sensor, and a GY-68 BMP180 digital barometric pressure sensor are connected to the serial data ports (SCL and SDA). The GY-8511 ultraviolet sensor uses the microcontroller's analog 0 (A0) and analog 1 (A1) pins. The MQ-135 air quality detection sensor operates connected to the analog 3 (A3) pin. The data obtained was instantly transferred to ThingSpeak, a free website developed for IoT applications. The ESP8266 wireless network module was used to transfer the data. This is an easy-to-use module powered by a 3.3-V adapter (Sparkfun, 2023). Figures 1 and 2 show the kit's design with SolidWorks.

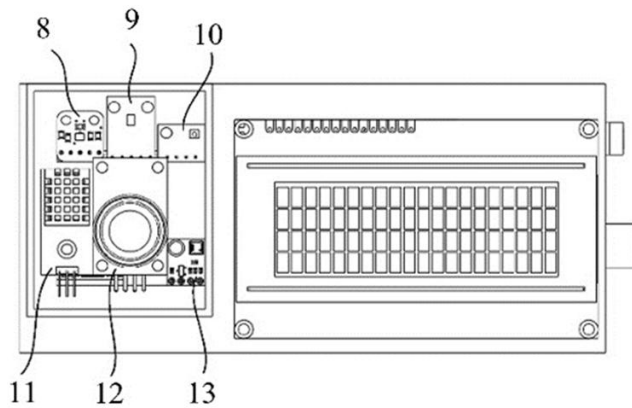

Figure-2. Visualization of the ambient parameters monitoring kit, 8) GY-8511, 9) TSL2561, 10) SGP30, 11) DHT11, 12) MQ-135, 13) GY-68 BMP180

The study used a handheld sensor to obtain NBI values

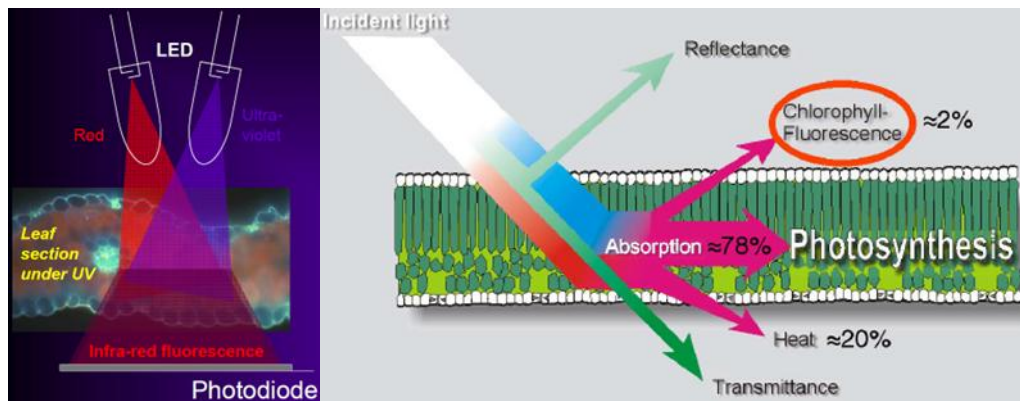

Figure-3. Working principle of the Force-A Dualex Scientific hand sensor (Force-A Dualex Scientific, 2023)

representing the chlorophyll/flavonol ratio, a measure of plant growth. This sensor, named Dualex, takes measurements from the leaf. The polyphenols it measures are considered indicators of the nitrogen utilization status of the plant. For example, under optimal conditions, a plant synthesizes chlorophyll and synthesizes proteins containing few flavonols. However, in the case of nitrogen deficiency, increased production of flavonols by the plant has been observed (Cerovic et al., 2012; Mattila et al., 2018; Overbeck et al., 2018). The parsley plant (*Petroselinum crispum*) was grown indoors in this study. The Parsley plant is produced to utilize its roots and leaves. It is rich in vitamin E and is an indispensable vegetable for meals and salads. It is essential in economic income by providing continuous income to producers throughout the year. Roots go 70-80 cm deep. There are many fringe roots around the root. Parsley makes a few side branches, and the number and size of leaves on the stem decreases from bottom to top. Parsley is not selective regarding soil requirements, so it is one of the preferred plants for soilless agriculture. pH values between 5.0 and 8.0 are suitable values. The most critical maintenance work to be done in parsley production is weed removal and irrigation, so maintenance work can be done in full and in the best way since there is no need for weed control in soilless agriculture, and irrigation can be provided by automation (Bayraktaroğlu et al., 2018). After the parsley plants were 15-20 cm, the first harvest was done by mowing 2 cm above the ground. Since the parsley plant requires a habitat of 60 to 100 plants per 1 m², approximately 1080 plants were grown. The working principle of the Dualex sensor used in the study is given in Figure 3.

Results

The developed kit was tested in the Soilless Agriculture Application and Automation Laboratory established within Ankara University, Faculty of Agriculture, Agricultural Machinery and Technologies Engineering. The experiment was carried out between January and April 2023. The area

where the experiment was conducted is fully controlled (coordinates 39.962013 and 32.867491). The system functioned stably and transferred data to the Internet environment. The ten-day average of the data obtained from the kit for 30 days is given in Table 1. The pictures of the ThingSpeak web page and the internet environment of the data were obtained by the kit and sent and saved via the Internet (Figure 4).

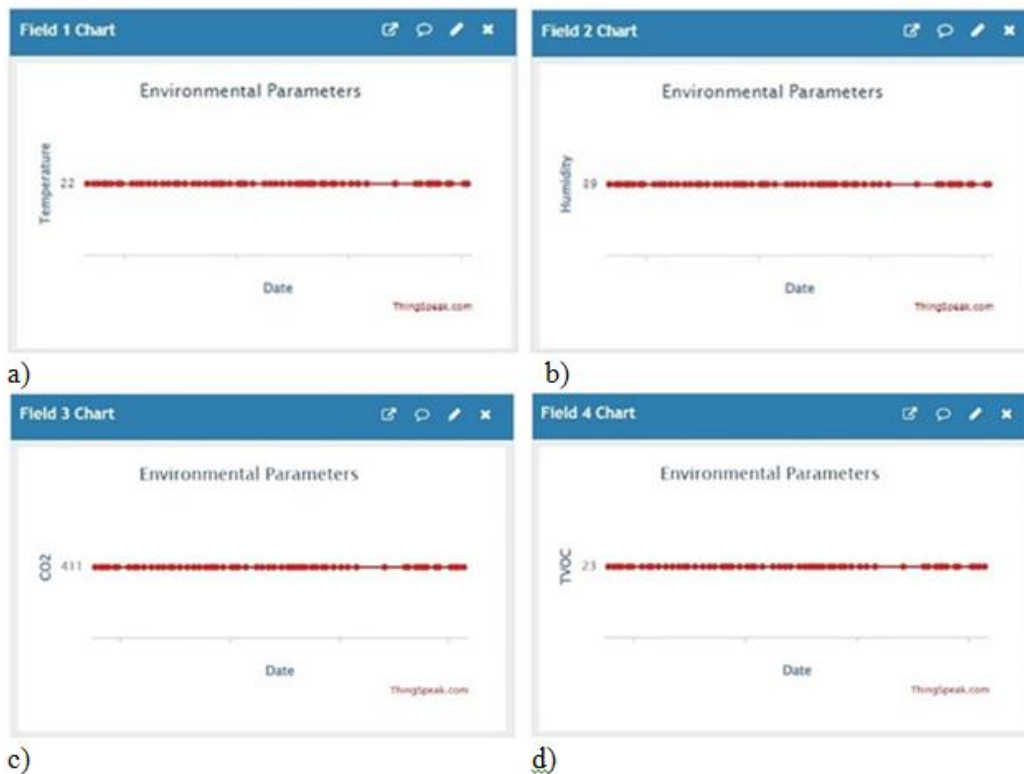
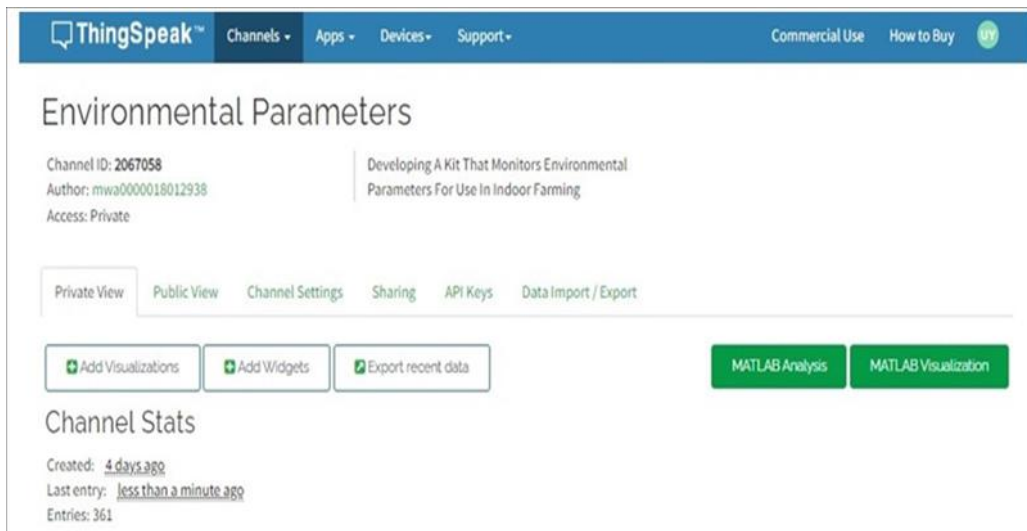

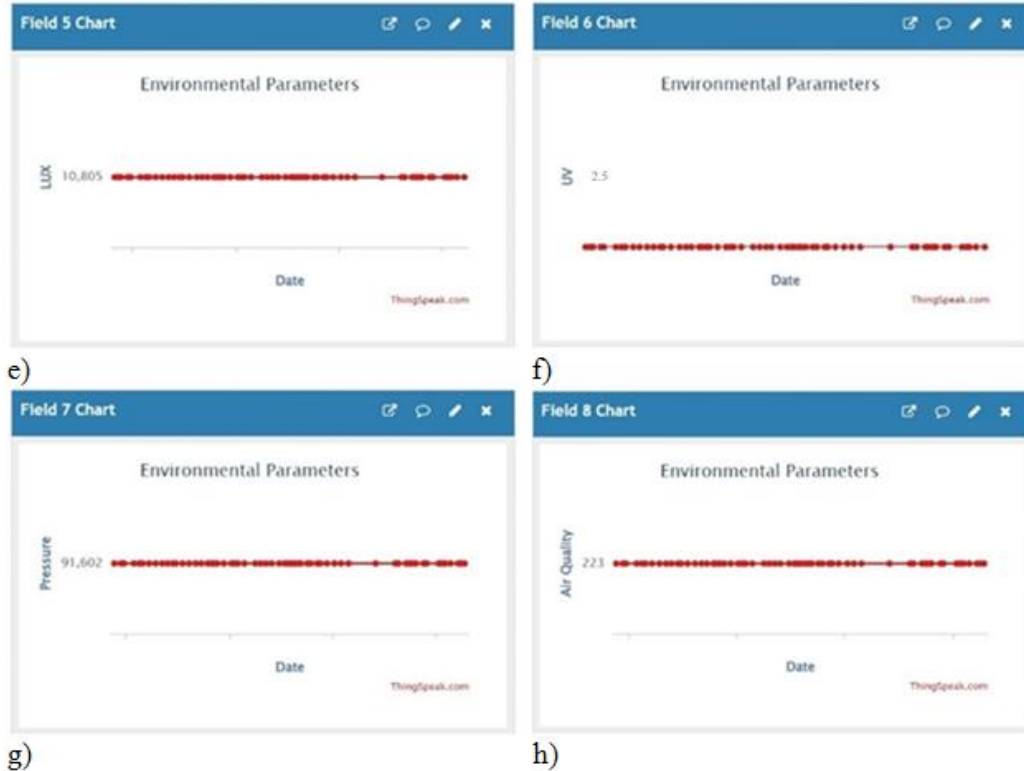

Figure-4. The ThingSpeak website where the data obtained from the kit is transferred and visuals of temperature (a) (°C), humidity (b) (%), CO₂ (c) (ppm), TVOC (d) (ppb), LUX (e) (Lux), UV (f) (W m⁻²), pressure (g) (Pa), and air quality (h) (ppm) values

Table-1. Ambient temperature (T), humidity (H), carbon dioxide CO₂, total volatile organic compounds (TVOC), light intensity (L), UV amount (UV), pressure (P), and air quality (AQ) values obtained from the developed kit for 30 days

Ort	T (°C)	H (%)	CO ₂ (ppm)	TVOC (ppb)	L (Lux)	UV (W m ⁻²)	P (Pa)	AQ (ppm)
1-10 days	22	39	411	22	10805	2.5	91602	223
11-20 days	22	39	414	23	10803	2.5	91603	225
21-30 days	22	39	416	24	10802	2.5	91601	226

Average values obtained; T (°C): 22 °C between 1 and 10 days, 22 °C between 11 and 20 days, and 22 °C between 21 and 30 days. The average H (%) values were 39%, CO₂ content was 411 ppm for the first ten days, 414 ppm between 11 and 20 days, and 416 ppm between 21 and 30 days. TVOC values were 22 ppb for the first ten days, 23 ppb between 11 and 20 days, and 24 ppb between 21 and 30 days. The ambient lighting intensity was 10805 Lux for the first ten days, 10803 Lux between 11 and 20 days, and 10802 Lux between 21 and 30 days. UV measurement results were stable and averaged 2.5 W m⁻². Ambient pressure was 91602 Pa for the first ten days, 91603 Pa between 11 and 20 days, and 91601 Pa for the last ten days. AQ values were 223 ppm for the first ten days, 225 ppm between 11 and 20 days, and 226 ppm for the last ten days.

Data was also collected with professional test devices from the beginning to the end of the study. These data were compared with the data obtained by the developed kit, and positive results were found. The statistical method is based on the intraclass correlation coefficient (ICC), usually between 0 and 1. It is a statistical tool applied in medical, psychological, biological, genetic, and agricultural research. The aim is to determine the margin of error of the device to be developed by determining the relationship between the values obtained from the device to be developed and the values obtained from the reference device. Linear relationships were found between the values obtained from the professional test devices and the values obtained from the kit; also, the results obtained are given in Figure 5.

A strong linear relationship was found between the values obtained with professional test equipment and the values obtained from the developed kit with $R^2=0.9021$ between T values, $R^2=0.889$ between H values, $R^2=0.8931$ between CO_2 values, $R^2=0.8931$ between CO_2 values, $R^2=0.8001$ between TVOC values, $R^2=0.882$ between Lux values, 0.8783 between UV values, 0.8526 between P values and $R^2=0.9505$ between AQ values. Parsley plants grow and reach harvest maturity in approximately 90 days. Chlorophyll

and flavanol values obtained every 10 days are given below. These values are given in Figures 7 to 15. All yield NBI and yield values obtained are given in Table 2. The highest yield value was 156.91 grams, with 12 hours on day⁻¹. The lowest yield value was determined to be 69.32 grams with 8 hours day⁻¹. In addition, Figure 6 shows the relationship ($R^2 = 0.9161$) between the NBI values obtained in the last harvest period and the yield values obtained.

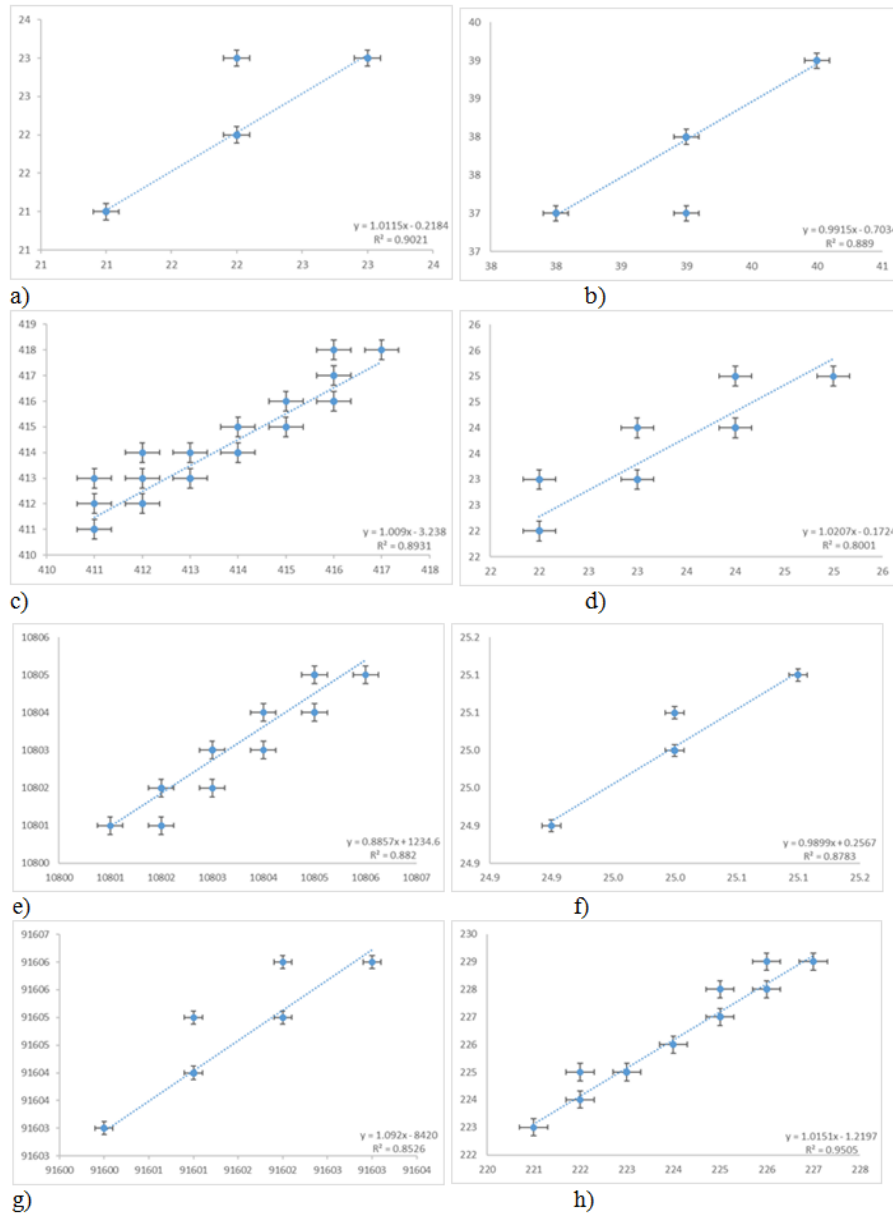

Figure-5. The relationship between the developed kit of T (a), H (b), CO_2 (c), TVOC (d), LUX (e), UV (f), P (g), and AQ (h) data and the values obtained from the professional test device

Table-2. NBI and yield values obtained according to daily artificial lighting duration

Duration of artificial lighting per day (hours)	NBI values	Yield (gr)
12	31.53	156.91
11	30.71	135.27
16	30.65	120.65
15	30.36	119.71
14	29.60	103.54
13	30.16	94.45
10	29.32	87.07
9	29.32	75.78
8	29.02	69.32

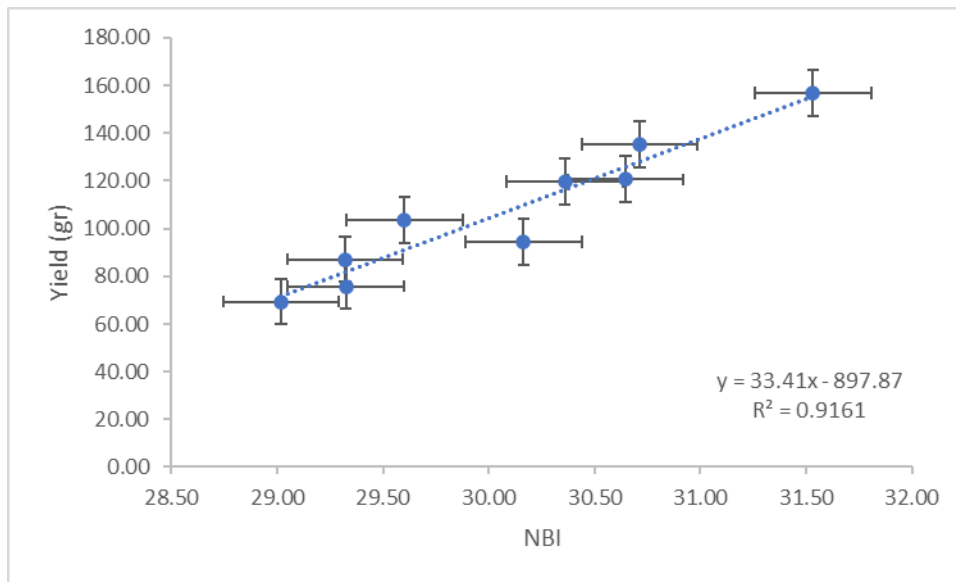

Figure-6. The relationship between NBI values obtained in the last harvest period and yield values obtained

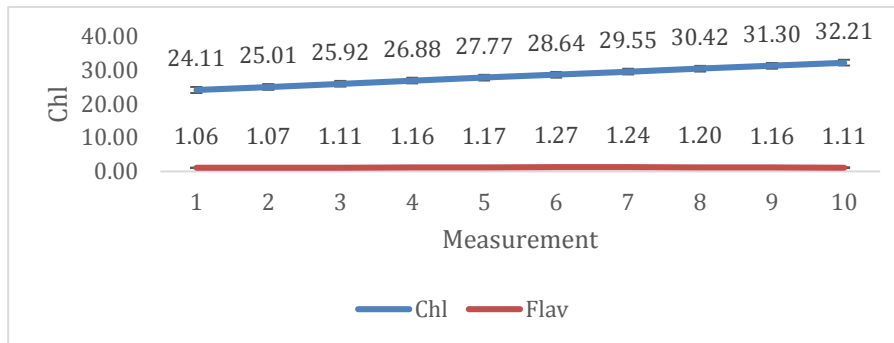

Figure-7. Chlorophyll and flavonol values obtained as a result of 8 hours day⁻¹ artificial lighting period

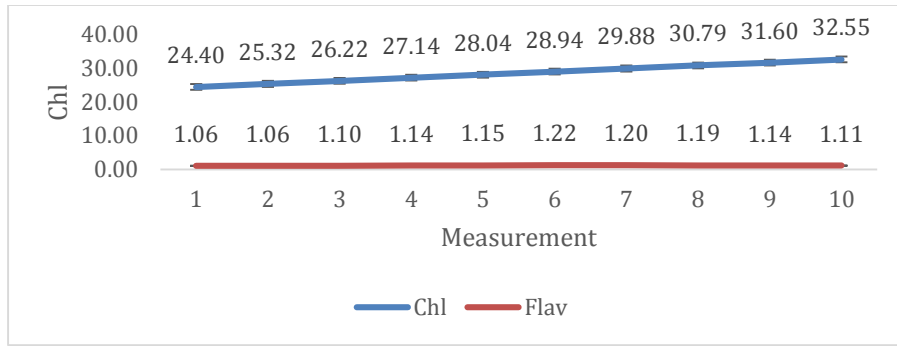

Figure-8. Chlorophyll and flavonol values obtained as a result of 9 hours day⁻¹ artificial lighting period

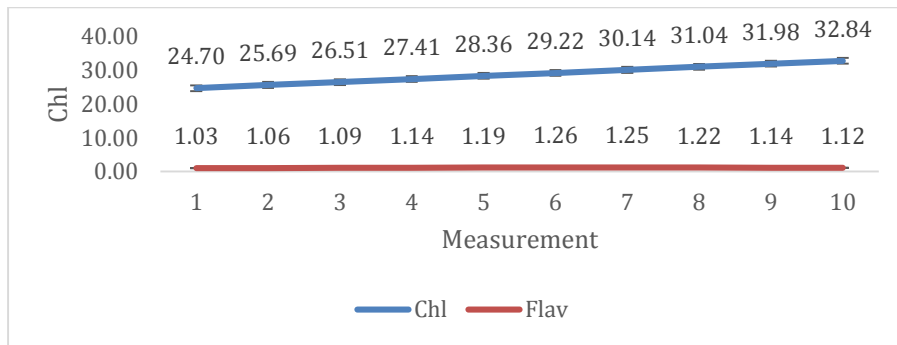

Figure-9. Chlorophyll and flavonol values obtained as a result of 10 hours day⁻¹ artificial lighting period

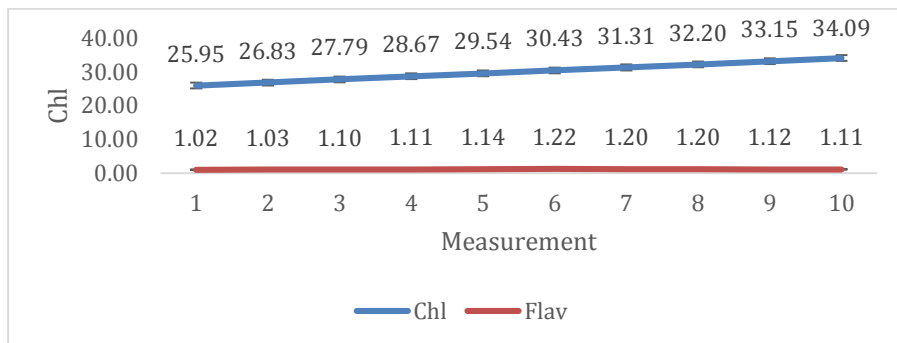

Figure-10. Chlorophyll and flavonol values obtained as a result of 11 hours day⁻¹ artificial lighting period

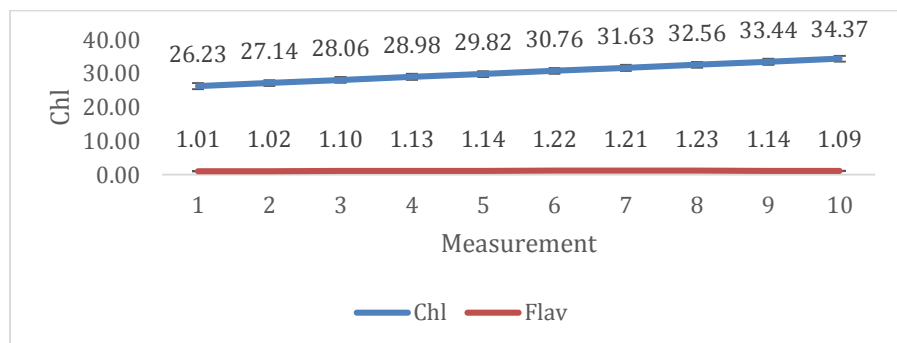

Figure-11. Chlorophyll and flavonol values obtained as a result of 12 hours day⁻¹ artificial lighting period

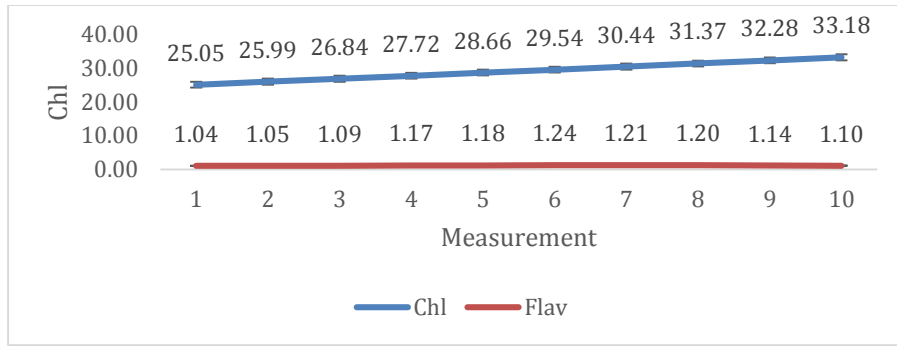

Figure-12. Chlorophyll and flavonol values obtained as a result of 13 hours day⁻¹ artificial lighting period

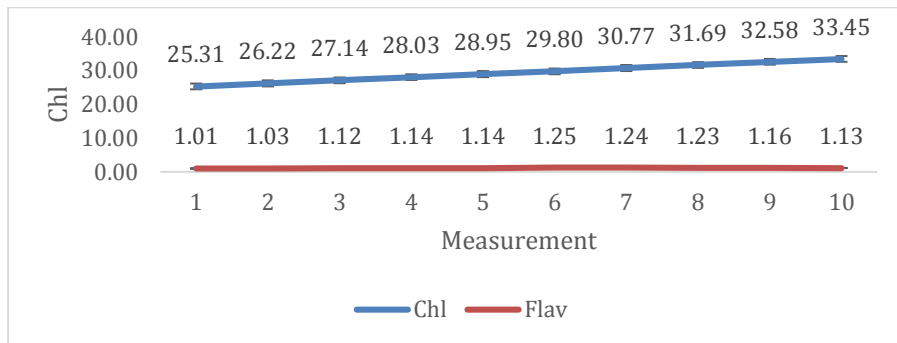

Figure-13. Chlorophyll and flavonol values obtained as a result of 14 hours day⁻¹ artificial lighting period

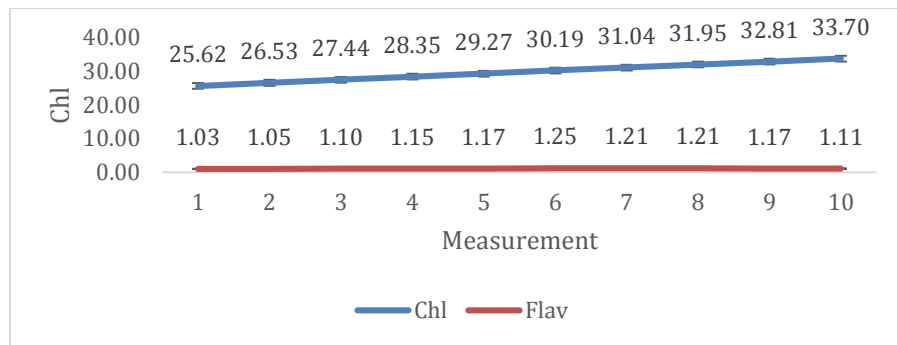

Figure-14. Chlorophyll and flavonol values obtained as a result of 15 hours day⁻¹ artificial lighting period

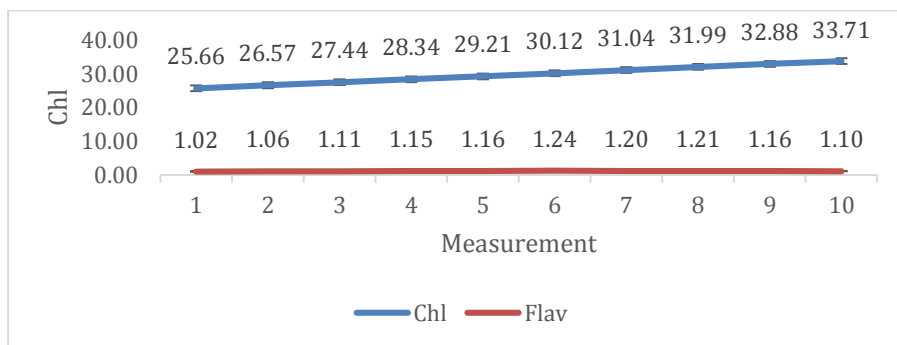

Figure-15. Chlorophyll and flavonol values obtained as a result of 16 hours day⁻¹ artificial lighting period

Discussion

An advanced irrigation management system uses real-time weather forecast data to control water in today's agricultural activities. Water use can also be managed through data from humidity sensors placed in agricultural areas with wi-fi connectivity, leading to water conservation. This approach was also adopted in the present study, allowing the user/farmer to control the control process anywhere in the world remotely. Controlled use of pesticides and fertilizers facilitates improving crop quality and minimizing the cost of agriculture. For controlled use, the possibility of damage to the product can be predicted by collecting the necessary data with IoT infrastructure. Also, since greenhouse gases increase the climate temperature, they can directly affect agricultural areas. Thus, product quality can be improved by monitoring greenhouse gases (Ray, 2017).

Water quality can be monitored with IoT-based devices that provide wireless communication. In the research on this subject, water quality can be monitored in real-time using IoT. Thus, physical and chemical parameters such as temperature, pH, turbidity, conductivity, and dissolved oxygen can be measured (Paventhan et al., 2012).

Precision agriculture is based on intensive monitoring of environmental conditions, sensing the necessary data, deciding on the final action, and computerizing the data obtained to control agricultural machinery (Nabi and Jamwal, 2017). In this context, wireless networks are an ideal method for monitoring environmental conditions that affect agricultural practices. Precision agriculture-based system design principles have been increasingly used in commercial projects that provide solutions for monitored crops, water supply for irrigation, fertilizer management, pest control, and automatic harvesting. Such systems can reduce costs through automation and cost savings (Dong et al., 2013).

Traditional irrigation methods and practices cause inefficient use of freshwater resources. As a result of these practices, the salinity level in the soil increases excessively and results in yield loss. It has been reported that IoT-smart agricultural technologies should be used and integrated into agricultural enterprises to irrigate efficiently (Karasekreter, 2011). In Germany, studies have been conducted on dynamic networks that can share data on precision agriculture, IoT, and forage crop production. A 2013 study developed a system that can control agricultural

irrigation applications using an ARM-based processor, GSM modem, and text messages (Blank et al., 2013). In 2014, a study conducted in Finland developed a system that can increase efficiency in agricultural production. This system can perform tasks such as data collection, machine control, data storage, weather, and disease forecasting (Pesonen et al., 2014).

Much work was done in 2015 in the name of IoT technologies. One is using IoT, big data, and cloud technologies in India. Another study focuses on integrating IoT technologies into irrigation, fertilization, and air conditioning systems for more efficient greenhouse production. At the same time, studies on wireless sensor network technologies have been carried out to monitor vegetable production and environmental factors in the greenhouse environment. A cost-effective monitoring system has been designed to track temperature, humidity, and light (Guo and Zhong, 2015; Srbinovska et al., 2015).

Vijayakumar and Ramy conducted a study on the quality and safety of drinking water. They developed and tested a system using IoT technologies to improve drinking water quality. It was reported that the system developed using Raspberry Pi works efficiently. In studies conducted in 2015 and 2016, it was stated that the monitoring and detection of plant diseases can be realized with IoT technologies and that temperature changes in closed cultivation systems can be measured and transferred to the Internet Internet, and a prototype was developed for this purpose (Vijayakumar and Ramy, 2015; Zaceping and Kviess, 2015; Türker et al., 2016)

Paul et al. developed hardware for farmers using the hydroponic farming method using an Arduino microcontroller to obtain pH, light, temperature, and humidity values and transmit this data to the user. The developed hardware was tested, and the data was accurately transferred to the user (Paul et al., 2018).

Pate and Hofstetter developed a device that can measure the CO₂ gas concentration in the air and provide information to the user, considering both animal and human health, especially for animal production enterprises. The researchers used an Arduino microcontroller to develop this device and determined that the values obtained were successfully transmitted to the user (Pate and Hofstetter, 2020).

Hofstetter et al. developed a data collection and control system for animal health in animal production farms. The system can detect and record carbon dioxide, ammonia gas concentrations, air temperature, and humidity (Hofstetter et al., 2022).



Ji et al. developed hardware to evaluate the ammonia and carbon dioxide concentrations of agricultural enterprises and the indoor air quality of the enterprise. The accuracy of the obtained data was tested and confirmed (Ji et al., 2014).

Drechsler et al. developed hardware to determine the development level and stress status of tomato plants grown in the field and measure variables such as wind speed, air temperature, relative humidity, and ultraviolet light. The developed hardware can transfer the data obtained using an image processing method to the Internet environment and can operate in an integrated manner with the irrigation system. The accuracy of the data obtained was tested, and it was determined that the hardware functioned correctly so that the plants could be grown in a healthy process (Drechsler et al., 2017)

Wu et al. developed an environment and pest monitoring system to increase crop production and quality in a greenhouse environment. Various sensors were used in the system, and the system had a stable Bluetooth connection and thus could operate continuously for approximately three months through an independent power supply (Wu et al., 2022).

Li et al. developed a device that can be used in agricultural facilities to detect parameters such as temperature, humidity, light intensity, and CO₂ concentration in the environment. Arduino and various sensors were used in the device's design, and the accuracy of the data obtained was tested (Li et al., 2017).

The Parsley plant was cultivated for the research because there is not enough data on the parsley plant in the literature, and it is a preferred plant in hydroponic systems because it is a plant with green parts. It has been reported that the most commonly grown plant species in hydroponic systems are basil, parsley, mint, dill, watercress, lettuce, and arugula (Rakocy et al., 2006). It is reported that the Photosynthetically Active Radiation (PAR) level should be between 50-350 $\mu\text{mol}\cdot\text{m}^{-2}\cdot\text{s}^{-1}$ in commercial greenhouses (Bugbee, 2016). Therefore, a PAR level of 331.2 $\mu\text{mol}\cdot\text{m}^{-2}\cdot\text{s}^{-1}$ was preferred in this study. As a result of the studies, it was reported that the amount of dissolved oxygen in closed systems should be between 3 mg L⁻¹ and 10 mg L⁻¹ (Rakocy, 2002; Rakocy et al., 2006). In this study, the preferred dissolved oxygen value in the growing medium was 6 mg L⁻¹. In addition, it was reported that the electrical conductivity value should be between 1 and 1.8 mS cm⁻¹ (Prince, 2023; Blackman, 2015). In this study, the

electrical conductivity value of the liquid in the system was chosen as 1.55 mS cm⁻¹. In studies on pH values, it has been reported that the pH value of the plant growing medium should be between 6.5 and 7 and that plants with abundant green parts generally thrive at 20-24 °C (Rakocy, 2002; Rakocy et al., 2006). Considering these studies, the pH value was set to 6.6, and the temperature of the liquid in the system was set to 22 °C.

In a study conducted to evaluate the effect of green light-emitting LED lamps with different wavelengths and light intensities on the growth and photosynthesis of plants with green parts, as a result of the illumination values applied at 100, 200, and 300 $\mu\text{mol m}^{-2} \text{s}^{-1}$, respectively, the growth of lettuce plants illuminated with 100 $\mu\text{mol m}^{-2} \text{s}^{-1}$ decreased compared to white fluorescent lamps. However, the root growth of plants illuminated with PPFD 200 $\text{m}^{-2} \text{s}^{-1}$ increased, and the highest increase was observed at PPF 300 $\text{m}^{-2} \text{s}^{-1}$. These results suggest high-intensity LED light effectively promotes plant growth (Johkan et al., 2010). This study preferred a lighting intensity close to or higher than 300 $\mu\text{mol m}^{-2} \text{s}^{-1}$.

Another study investigated the effect of artificial lighting quality on plant biomass and chlorophyll accumulation. Artificial illumination with fluorescent light was performed in the growth chamber for 20 days. Full-spectrum white light was reported to be effective on plant growth and yield parameters (Lin et al., 2013).

In another study, according to the data obtained, the effects of different artificial lighting durations and intensities were investigated in order to increase leaf number, leaf length, leaf area, and yield values, and it was determined that 300 $\mu\text{mol m}^{-2} \text{s}^{-1}$ and 12 h day⁻¹ application doses increased these parameters (Chang and Chang, 2014).

Conclusion

The average values obtained from the developed kit are as follows: temperature 22°C, humidity 39%, CO₂ 414 ppm, TVOC 23 ppb, light intensity 10803 Lux, UV 2.5 W/m², pressure 91602 Pa, and air quality 224 ppm. It was understood that IoT technologies need further agricultural studies and that more data to be obtained can contribute to resolving more problems. The kit obtained in the study can be used in domestic agriculture and all kinds of agricultural activities. The hardware used in the kit's design is relatively



affordable and easy to use. Six different sensors used in the kit's design facilitate obtaining eight different data and transferring this data to the Internet environment completely free of charge. It was concluded that the kit could operate smoothly and stably and be employed for data recording and early warning for various agricultural activities.

Disclaimer: None.

Conflict of Interest: None.

Source of Funding: None.

References

- Arduino, 2023. Complete URL (<http://store.arduino.cc/products/arduino-mega-2560-rev3/>)
- Bac CW, Hemming J, Tuijl BAJ, Barth R, Wais E and Henten EJ, 2017. Performance evaluation of a harvesting robot for sweet pepper. *J. Field Robot.* 34: 1123-1139. DOI: <https://doi.org/10.1002/rob.21709>
- Bayraktaroğlu ÖY, Saatçı Mordoğan N and Bayız O, 2018. Effects of iron fertilizers on iron content of parsley. *Ege J. Agric. Res.* 55(4): 463-470. DOI: <https://doi.org/10.20289/zfdergi.416883>
- Blackman C, 2015. Playing by the rules: biochemical sequence, nutrient antagonism. Complete URL (<https://www.linkedin.com/pulse/playing-rules-biochemical-sequence-nutrient-caitlin-blackman/>)
- Blank S, Bartolein C, Meyer A, Ostermeier R and Rostanin O, 2013. iGreen: a ubiquitous dynamic network to enable manufacturer in dependent data exchange in future precision farming. *Comput. Electron. Agric.* 98: 109-116. DOI: <https://doi.org/10.1016/j.compag.2013.08.001>
- Bugbee B, 2016. Toward an optimal spectral quality for plant growth and development: the importance of radiation capture. *Acta. Hort.* 1134: 1-12. DOI: <https://doi.org/10.17660/ActaHortic.2016.1134.1>
- Cerovic ZG, Masdoumier G, Ghazlen NB and Latouche G, 2012. A new optical leaf-clip meter for simultaneous non-destructive assessment of leaf chlorophyll and epidermal flavonoids. *Physiol. Plant.* 146: 251-260. DOI: <https://doi.org/10.1111/j.1399-3054.2012.01639.x>
- Chang CL and Chang KP, 2014. The growth response of leaf lettuce at different stages to multiple wavelength-band light-emitting diode lighting. *Sci. Hortic.* 179: 78-84. DOI: <https://doi.org/10.1016/j.scienta.2014.09.013>
- Corchado JM, 2018. A framework for knowledge discovery from wireless sensor networks in rural environments: a crop irrigation systems case study. *Wirel. Commun. Mob. Comput.* 6089280. DOI: <https://doi.org/10.1155/2018/6089280>
- Dong X, Vuran MC and Irmak S, 2013. Autonomous precision agriculture through integration of wireless underground sensor networks with center pivot irrigation systems. *Ad. Hoc. Networks.* 11: 1975-1987. DOI: <https://doi.org/10.1016/j.adhoc.2012.06.012>
- Drechsler KM, Ko-Madden CT, Schramm AE, Rojo FE and Upadhyaya SK, 2017. Remote field crop water stress monitor. *ASABE*, 1700903. DOI: <https://doi.org/10.13031/aim.201700903>
- Force-A Dualex Scientific, 2023. Itk Company. Complete URL (<https://www.itk.fr/en/>)
- Guo T and Zhong W, 2015. Design and implementation of the span greenhouse agriculture internet of things system, pp. 398-401. In *Proceedings, 2015 International Conference on Fluid Power and Mechatronics (FPM)*, 5-7 August 2015, Harbin, China.
- Hofstetter D, Lorenzoni G and Fabian E, 2022. An arduino based all-in-one data acquisition and control system for poultry health research. *ASABE*, 2200343. DOI: <https://doi.org/10.13031/aim.202200343>
- Ji B, Gates RS, Green AR and Guo X, 2014. Upgrade of portable monitoring system for continuous environmental monitoring in the field. *ASABE*, 141899399. DOI: <https://doi.org/10.13031/aim.20141899399>
- Jia C, Cao K, Valaulikar R, Fu X and Sorin AB, 2019. Variability of total volatile organic compounds (tvoc) in the indoor air of retail stores. *Int. J. Environ. Res. Public Health.* 16: 4622. DOI: <https://doi.org/10.3390/ijerph16234622>
- Johkan M, Shoji K, Goto F, Hashida S and Yoshihara T, 2010. Blue light-emitting diode light irradiation of seedlings improves seedling quality and growth after transplanting in red leaf lettuce. *HortScience* 45: 1809-1814. DOI: <https://doi.org/10.21273/HORTSCI.45.12.1809>
- Karasekreter N, 2011. Realized and application of gsm/sms based automated irrigation control unit. *Eng. Sci.* 6: 71-77. DOI: <https://doi.org/10.12739-nwsaes.v6i1.5000067009-186245>
- Li M, Ma J, Jia W and Zhang H, 2017. A design and implementation of facilities agriculture



- environment monitoring system based on single-chip. ASABE, 1700938. DOI: <https://doi.org/10.13031/aim.201700938>
- Lin KH, Hsu CY, Huang YP, Lai JY, Hsieh WB, Huang MY, Yang CM and Chao PY, 2013. Chlorophyll-related compounds inhibit cell adhesion and inflammation in human aortic cells. *J. Med. Food.* 16(10): 886-898. DOI: <https://doi.org/10.1089/jmf.2012.2558>
- Loconsole D and Santamaria P, 2021. UV lighting in horticulture: a sustainable tool for improving production quality and food safety. *Horticulturae*, 7: 1-9. DOI: <https://doi.org/10.3390/horticulturae7010009>
- Makerfabs, 2023. Shenzhen Makerfabs Corporation. Complete URL (<https://www.makerfabs.com/sgp30-air-quality-sensor-breakout.html/>).
- Mattila H, Valev D, Havurinne V, Khorobrykh S, Virtanen O, Antinluoma M, Mishra KB and Tyystjärvi E, 2018. Degradation of chlorophyll and synthesis of flavonols during autumn senescence—the story told by individual leaves. *AoB PLANTS*, 10: 3. DOI: <https://doi.org/10.1093/aobpla/ply028>
- Morchid A, El Alami R, Raedah AA and Sabbar Y, 2023. Applications of internet Internets (IoT) and sensors technology to increase food security and agricultural Sustainability: Benefits and challenges. *Ain Shams Eng. J.* 102509. DOI: <https://doi.org/10.1016/j.asej.2023.102509>
- Nabi F and Jamwal S, 2017. Wireless sensor networks and monitoring of environmental parameters in precision agriculture. *Int. J.* 7: 432-437. DOI: <https://doi.org/10.23956/ijarcsse/SV7I5/0344>
- Oberti R, Marchi M, Tirelli P, Calcante A, Iriti M, Tona W, Hoevar M, Baur J, Pfaff J and Schütz C, 2016. Selective spraying of grapevines for disease control using a modular agricultural robot. *Biosyst. Eng.* 146: 203-215. DOI: <https://doi.org/10.1016/j.biosystemseng.2015.12.004>
- Overbeck V, Schmitz M, Tartachnyk I and Blanke M, 2018. Identification of light availability in different sweet cherry orchards under cover by using non-destructive measurements with a Dualex™. *Eur. J. Agron.* 93: 50-56. DOI: <https://doi.org/10.1016/j.eja.2017.11.006>
- Pate ML and Hofstetter D, 2020. A one-health approach to safety instruction: a framework for livestock housing environment monitoring using arduino-based sensors. ASABE, 2000240. DOI: <https://doi.org/10.13031/aim.202000240>
- Paul OK, Mao H and Li L, 2018. New type arduino plant grower (GCKJ). ASABE, 1800016. DOI: <https://doi.org/10.13031/aim.201800016>
- Paventhana A, Allu SK, Barve S, Gayathri V and Ram NM, 2012. Soil property monitoring using 6lowpan-enabled wireless sensor networks, pp. 277-282. In *Proceedings, 2012 Agro Informatics and Precision Agriculture*, August 2012, Bangalore, India.
- Pesonen LA, Teye FKW, Ronkainen AK, Koistinen MO, Kaivosoja JJ, Suomi PF and Linkolehto RO, 2014. Cropinfra: An Internet-based service infrastructure to support crop production in future farms. *Biosyst. Eng.* 120: 92-101. DOI: <https://doi.org/10.1016/j.biosystemseng.2013.09.005>
- Prince R, 2023. Plant Nutrients. Complete URL (<http://www.ncagr.gov/cyber/kidswrld/plant/nutrient.htm/>)
- Rakocy JE, Masser MP and Losordo TM, 2006. Recirculating aquaculture tank production systems: aquaponics-integrating fish and plant culture. SRAC Publication, 454.
- Rakocy JE, 2002. An Integrated Fish and Field Crop System for Arid Areas, In: *Ecological Aquaculture: The Evolution of the Blue Revolution*, Editor: Costa-Pierce, B.A., Blackwell Science Ltd, Oxford, UK, pp. 263-285. DOI: <https://doi.org/10.1002/9780470995051.ch9>
- Ray PP, 2017. Internet of things for smart agriculture: technologies, practices and future direction. *J Amb Intel Smart Ee.* 9: 395-420. DOI: <https://doi.org/10.3233/AIS-170440>
- Reza AW, Jannat KS, Islam MDS and Barman SD, 2022. Smart pre-seeding decision support system for agriculture. *J. Inf. Syst. Telecommun.* 139911 18262073. DOI: <https://doi.org/10.52547/jist.15698.10.38.102>
- Schnitzler WH, 2004. Pest and disease management of soilless culture. *Acta Hort.* 648(72): 191-203. DOI: <https://doi.org/10.17660/ActaHortic.2004.648.23>
- Snowden MC, Cope KR and Bugbee B, 2016. Sensitivity of seven diverse species to blue and green light: interactions with photon flux. *Plos One*, 11: 10. DOI: <https://doi.org/10.1371/journal.pone.016312>
- Sparkfun, 2023. SparkFun Electronics. Complete URL (<https://www.sparkfun.com/products/retired/21240/>)
- Srbinska M, Gavrovski C, Dimcev V, Krkoleva A and Borozan V, 2015. Environmental parameters



- monitoring in precision agriculture using wireless sensor networks. *J. Clean. Prod.* 88: 297–307. DOI: <https://doi.org/10.1016/j.jclepro.2014.04.036>
- Türker U, Uğur F and Dayıoğlu MA, 2016. Implementation of internet Internets technology in greenhouses: design and prototyping. *JAFAG* 33: 52-60.
- Vijayakumar N and Ramy R, 2015. The real-time monitoring of water quality in IoT, pp. 1-4. In *Proceedings, International Conference on Circuit, Power and Computing Technologies (ICCPCT)*, 19-20 March 2015, Nagercoil, India.
- Villarrubia G, Paz JFD, Iglesia DHDL and Bajo J, 2017. Combining multi-agent systems and wireless sensor networks for monitoring crop irrigation. *Sensors.* 17: 1775. DOI: <https://doi.org/10.3390/s17081775>
- Wu YT, Wu YF, Chen SK, Chung JY and Lin TT, 2022. Design of a versatile wireless multi-sensor interface for the intelligent environmental and pest monitoring system. *ASABE*, 2200453. DOI: <https://doi.org/10.13031/aim.202200453>
- Zaceping A and Kviess A, 2015. System architectures for real-time bee colony temperature. *Procedia Comput. Sci.* 43: 86-94. DOI: <https://doi.org/10.1016/j.procs.2014.12.012>